



wheel-mounted
for drums **180/220 kg**



Art. 45180

Art. 45180 Suction drainer / dispenser with pump, wheel-mounted
Composed of:
pump equipped with vacuum gauge; Trolley for 180/220 kg drums
2 m. suction/delivery hoses series of probes (art. 45560) plus
probe \varnothing 12 (art. 45540)

N° 2 packing m^3 0,113 kg 32,1

Article	45180
Pump suction ratio 1:1	33060
Max. pressure air to pump	6 bar
Noise level	81 dB
Trolley art. 80200	180/220 kg
Length suction hose	1/2" x 2 m
Length draining hose	1/2" x 2 m
Suction speed with oil at 70-80°C, probes 6 mm.	1,5 - 2 lt/min

WARNING: Do not use flammable or corrosive liquids.

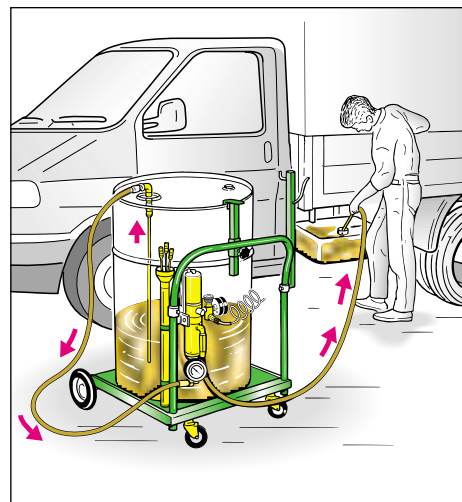
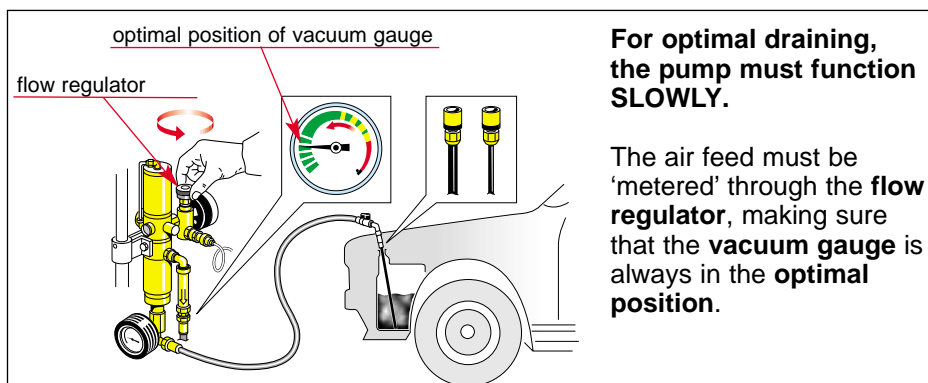

The **wheel-mounted pump drainers** are used to drain and deliver the liquid previously drained. The air-operated pump is equipped with **special teflon seals** making it suitable for draining various oils, depleted oil antifreeze liquid, diesel oil and allied products, from any vehicle and machine in general, and/or their delivery.

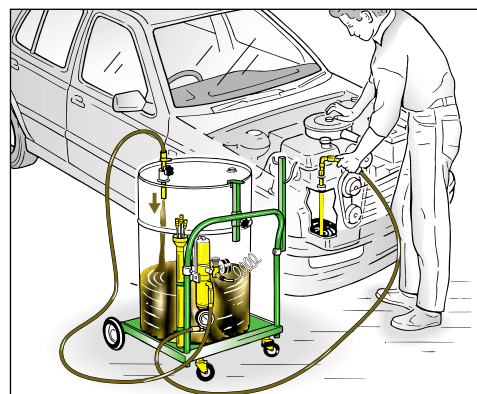

Engine oil must be drained when the oil is still hot (70/80 °C)

Overall dimensions

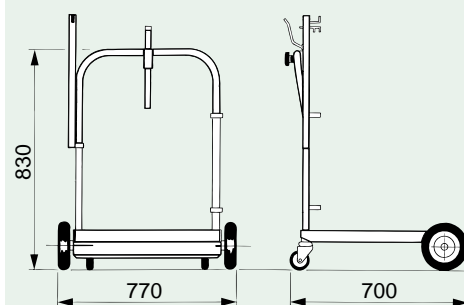

art. 45180

SUCTION STAGE

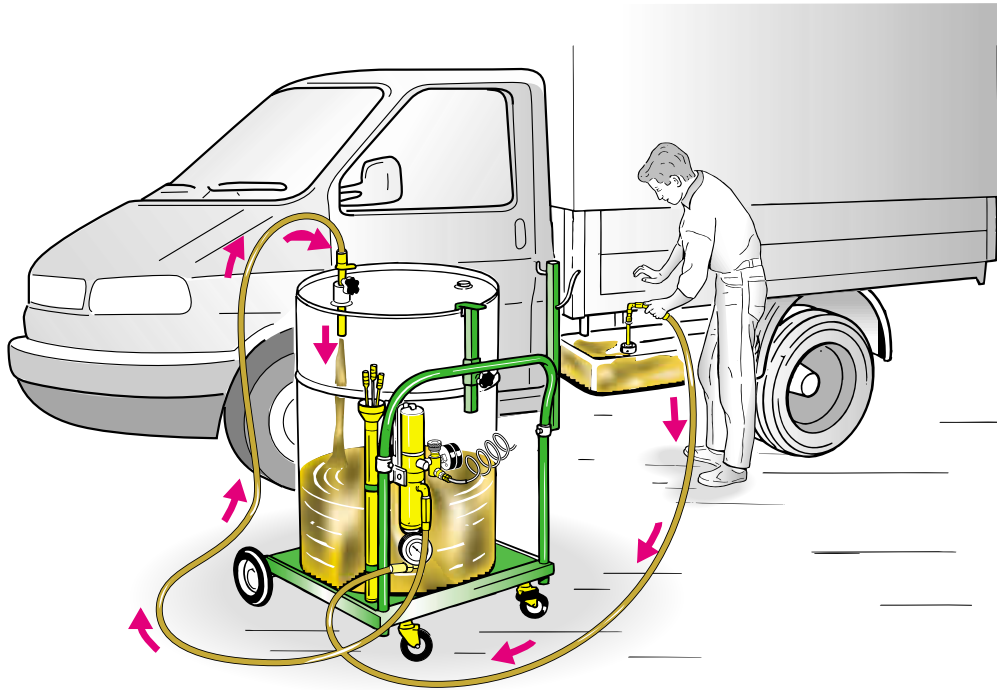

Draining occurs by means of a probe specially chosen from those supplied.

Draining of lubricating oil or antifreeze liquid at room temperature must be done using the special flexible probe of diameter 12 mm.

DELIVERY STAGE OF DRAINED LIQUID

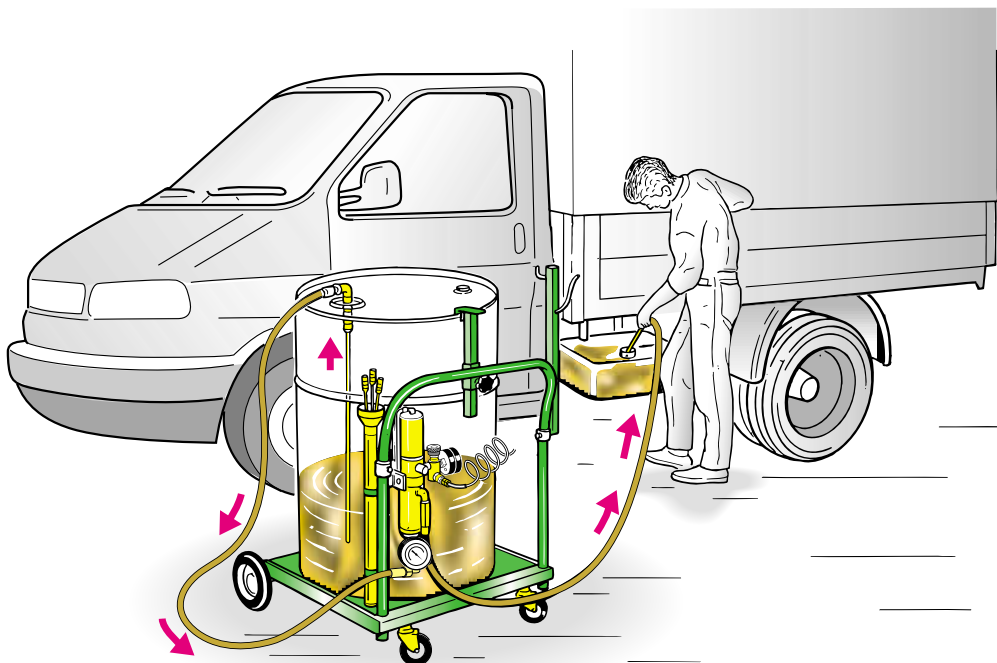

Delivery of the liquids sucked occurs simple by reversing the position of the two draining tubes.

The suction tube must be inserted in the drained liquid container.

The suction tube must be inserted in the container just emptied.