

with **central pump**  
and **open hose reel**

**Kit for dispensing from tank.**

A complete solution for dispensing oil and allied products.

The dispensing pump and the enclosed hose reel are fixed directly to the tank by means of sturdy brackets.



**Note:** The tank is not part of the Kit

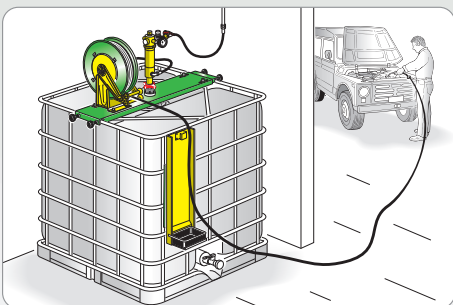

Art. 36610 (R 3:1 - 14 l/min)

Art. 36620 (R 5:1 - 18 l/min)

Art. 36630 (R 7:1 - 30 l/min)

**Art. 36610**

**Dispensing kit for oil and allied products with pump inserted centrally and enclosed hose reel, complete with:**

- Art. 35163 pump R 3:1 - 14 l/min
- Art. 36601 support bracket
- Art. 8430.401 hose reel with 10 m hose  $\varnothing$  1/2"
- Art. 37735 meternig gun
- Art. 38071 nipple 1/2" x 1/2" G M/M
- Art. 88630 drip tray

No. 4 packing  $m^3$  0,250 kg 48

**Art. 36620**

**Dispensing kit for oil and allied products, equipped like Art. 36610 but with pump:**

- Art. 36063 pump R 5:1 - 18 l/min

No. 4 packing  $m^3$  0,250 kg 49

**Art. 36630**

**Dispensing kit for oil and allied products with pump inserted centrally and enclosed hose reel complete with:**

- Art. 92C/71 pump R 7:1 - 30 l/min
- Art. 36601 support bracket
- Art. 8540.401 hose reel with 15 m hose  $\varnothing$  3/4"
- Art. 37771 meternig gun
- Art. 33119 nipple 1" x 3/4" G M/M
- Art. 10/15 bung adaptor  $\varnothing$  53
- Art. 88630 drip tray

No. 4 packing  $m^3$  0,270 kg 70

● Art. 92C/71

(for Art 36630)

● Art. 35163

(for Art 36610)

● Art. 36063

(for Art 36620)

● Art. 38071

● Art. 33119

● Art. 10/15

● Art. 8430.401

(for Art 36610 - 36620)

● Art. 8540.401

(for Art 36630)

● Art. 37771

(for Art 36630)

● Art. 37735

(for Art 36610 - 36620)

