



for drums **180/220 kg**  
with **HOSE REEL**



Art. 37100 (R.5:1-18 lt/min)

Art. 35200 (R.3:1-14 lt/min)

**The platform** is equipped with:  
trolley with drum quick-clamping/release device; adjustable side support for hooking gun and hose;  
with braked wheels;  
other accessories.

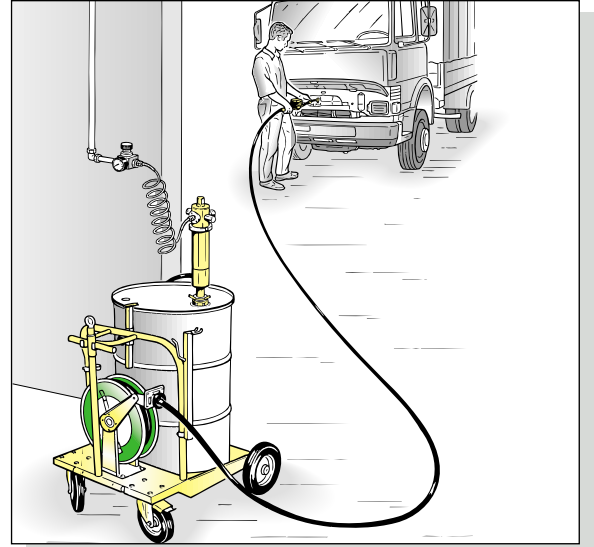

**Mobile oil dispenser platform:** the most practical and complete combination for dispensing oil of any density and in any workplace (workshop, farming, industry, etc.) determined both by the easy to handle trolley and the practical hose reel with its 10 metres of hose.

**Art. 37100 Mobile oil dispenser platform with hose reel** for 180/220 kg trade drums composed of:

- art. 36094 Pump 18 l/min R 5:1
- art. 80201 Trolley 220 kg
- art. 81512 Hose reel 10 m 1/2"
- art. 38042 Bung adaptor
- art. 38071 Nipples 1/2"x1/2"G. M/M
- art. 37713 Digital meter gun
- art. 91202 Connection hose

N° 4 packing    m<sup>3</sup> 0,210    kg 73,4

**Art. 35200 Mobile oil dispenser platform with hose reel** for 180/220 kg trade drums same as art. 37100 but with pump art. 35194 **14 lt/min R. 3:1**

N° 4 packing    m<sup>3</sup> 0,210    kg 72,2

**Note:** The same platform can be supplied on request, at different price, with hose reel (art. 81514) equipped with 1/2" hose, length 15 metres.

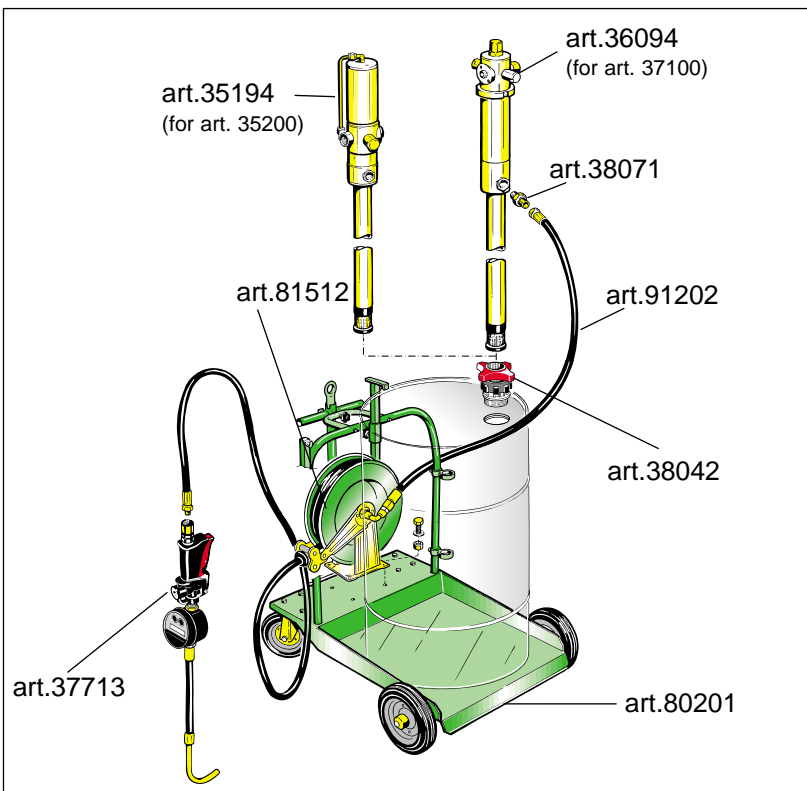

#### Overall dimensions

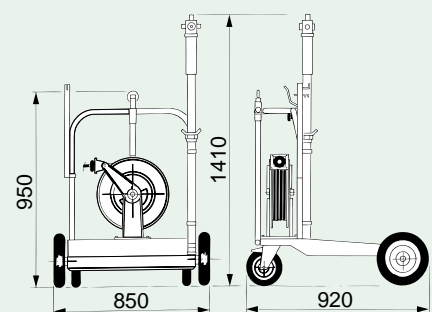

art. 37100 - 35200