



wheel-mounted
for drums **20/220 kg**



Art. 42050 (20/60 kg)

Art. 42000 (180/220 kg)

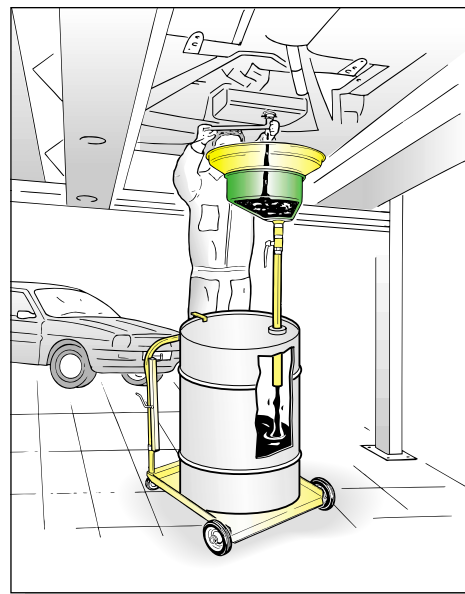

Wheel-mounted oil drainers for container of various types, tanks and drums of all sizes up to 220 kg. Practical and functional, suitable for gravity draining of engine, gearbox and differential oil from all motor vehicles placed on auto lift or pit. The height-adjustable collection bowl (capacity 13 litres) is mounted on a swivel joint facilitating optimal positioning for work.

Art. 42050 Waste oil drainer for tanks or drums composed of:
art. 80050 Trolley for 20/60 kg containers
collection bowl with oversize funnel
antisplash screen/filter

N° 2 packing m^3 0,120 kg 17

Art. 42000 Waste oil drainer for drums composed of:
art. 80200 Trolley for 180/220 kg drums
collection bowl with oversize funnel
antisplash screen/filter
drum clamping ring

N° 2 packing m^3 0,150 kg 29

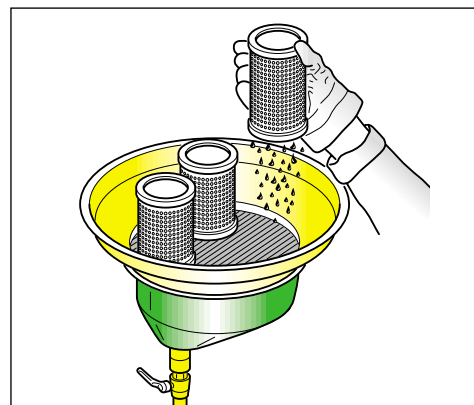

In addition to serving as a filter, the antisplash screen is also a useful support for draining the filters just changed.

Article	42050	42000
Trolley capacity	20/60 Kg	180/220 Kg
Bowl capacity	13 lt	13 lt
Diameter oversize funnel	580 mm	580 mm
Maximum height	1800 mm	1800 mm
Minimum height	1200 mm	1300 mm

Overall dimensions

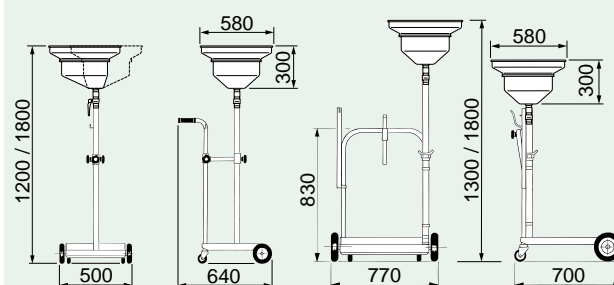

art. 42050

art. 42000

Warning: Do not use flammable or corrosive liquids.

